

DIPARTIMENTO DI MATEMATICA
“Francesco Brioschi”
POLITECNICO DI MILANO

**Sharp bounds for the p -torsion of
convex planar domains**

Fragal, I.; Gazzola, F.; Lamboley, J.

Collezione dei *Quaderni di Dipartimento*, numero **QDD 117**
Inserito negli *Archivi Digitali di Dipartimento* in data 30-1-2012



Piazza Leonardo da Vinci, 32 - 20133 Milano (Italy)

Sharp bounds for the p -torsion of convex planar domains

Ilaria FRAGALÀ - Filippo GAZZOLA - Jimmy LAMBOLEY

Abstract

We obtain some sharp estimates for the p -torsion of convex planar domains in terms of their area, perimeter, and inradius. The approach we adopt relies on the use of web functions (*i.e.* functions depending only on the distance from the boundary), and on the behaviour of the inner parallel sets of convex polygons. As an application of our isoperimetric inequalities, we consider the shape optimization problem which consists in maximizing the p -torsion among polygons having a given number of vertices and a given area. A long-standing conjecture by Pólya-Szegő states that the solution is the regular polygon. We show that such conjecture is true within the subclass of polygons for which a suitable notion of “asymmetry measure” exceeds a critical threshold.

2000MSC : 49K30, 52A10, 49Q10.

Keywords : isoperimetric inequalities, shape optimization, web functions, convex shapes.

1 Introduction

Let $\Omega \subset \mathbb{R}^2$ be an open bounded domain and let $p \in (1, +\infty)$. Consider the boundary value problem

$$\begin{cases} -\Delta_p u = 1 & \text{in } \Omega \\ u = 0 & \text{on } \partial\Omega, \end{cases} \quad (1)$$

where $\Delta_p u = \operatorname{div}(|\nabla u|^{p-2} \nabla u)$ denotes the p -Laplacian. The p -torsion of Ω is defined by

$$\tau_p(\Omega) := \int_{\Omega} |\nabla u_p|^p = \int_{\Omega} u_p, \quad (2)$$

being u_p the unique solution to (1) in $W_0^{1,p}(\Omega)$. Notice that the second equality in (2) is obtained by testing (1) by u_p and integrating by parts. Since (1) is the Euler-Lagrange equation of the variational problem

$$\min_{u \in W_0^{1,p}(\Omega)} J_p(u), \quad \text{where } J_p(u) = \int_{\Omega} \left(\frac{1}{p} |\nabla u|^p - u \right), \quad (3)$$

there holds

$$\tau_p(\Omega) = \frac{p}{1-p} \min_{u \in W_0^{1,p}(\Omega)} J_p(u).$$

A further characterization of the p -torsion is provided by the equality $\tau_p(\Omega) = S(\Omega)^{1/(p-1)}$, where $S(\Omega)$ is the best constant for the Sobolev inequality $\|u\|_{L^1(\Omega)}^p \leq S(\Omega) \|\nabla u\|_{L^p(\Omega)}^p$ on $W_0^{1,p}(\Omega)$.

The purpose of this paper is to provide some sharp bounds for $\tau_p(\Omega)$, holding for a convex planar domain Ω , in terms of its area, perimeter, and inradius (in the sequel denoted respectively by $|\Omega|$, $|\partial\Omega|$, and R_{Ω}). The

original motivation for studying this kind of shape optimization problem draws its origins in the following long-standing conjecture by Pólya and Szegő:

$$\textit{Among polygons with a given area and } N \textit{ vertices, the regular } N\text{-gon maximizes } \tau_p . \quad (4)$$

A similar conjecture is stated by the same Authors also for the principal frequency and for the logarithmic capacity, see [13]. For $N = 3$ and $N = 4$ these conjectures were proved by Pólya and Szegő themselves [13, p. 158]. For $N \geq 5$, to the best of our knowledge, the unique solved case is the one of logarithmic capacity, see the beautiful paper [14] by Solynin and Zalgaller; the cases of torsion and principal frequency are currently open. In fact let us remind that, for $N \geq 5$, the classical tool of Steiner symmetrization fails because it may increase the number of sides, see [9, Section 3.3].

The approach we adopt in order to provide upper and lower bounds for the p -torsion in terms of geometric quantities, is based on the idea of considering a proper subspace $\mathcal{W}_p(\Omega)$ of $W_0^{1,p}(\Omega)$ and to address the minimization problem for the functional J_p on $\mathcal{W}_p(\Omega)$. More precisely, we consider the subspace of functions depending only on the distance $d(x) = \text{dist}(x, \partial\Omega)$ from the boundary:

$$\mathcal{W}_p(\Omega) = \{u \in W_0^{1,p}(\Omega) : u(x) = u(d(x))\} .$$

Functions in $\mathcal{W}_p(\Omega)$ have the same level lines as d , namely the boundaries of the so-called *inner parallel sets*, $\Omega_t := \{x \in \Omega : d(x) > t\}$, which were first used in variational problems by Pólya and Szegő [13, Section 1.29]. Later, in [8], the elements of $\mathcal{W}_p(\Omega)$ were called *web functions*, because in case of planar polygons the level lines of d recall the pattern of a spider web. We refer to [5, 6] for some estimates on the minimizing properties of these functions, and to the subsequent papers [3, 4] for their application in the study of the generalized torsion problem. Actually, the papers [3, 4] deal with the problem of estimating how efficiently $\tau_p(\Omega)$ can be approximated by the *web p -torsion*, defined as

$$w_p(\Omega) := \frac{p}{1-p} \min_{u \in \mathcal{W}_p(\Omega)} J_p(u) .$$

While the value of $\tau_p(\Omega)$ is in general not known (because the solution to problem (1) cannot be determined except for some special geometries of Ω), the value of $w_p(\Omega)$ admits the following explicit expression in terms of the parallel sets Ω_t :

$$w_p(\Omega) = \int_0^{R_\Omega} \frac{|\Omega_t|^q}{|\partial\Omega_t|^{q-1}} dt , \quad (5)$$

where $q = \frac{p}{p-1}$ is the conjugate exponent of p , and R_Ω is the inradius of Ω (see [4]).

Clearly, since $\mathcal{W}_p(\Omega) \subset W_0^{1,p}(\Omega)$, $w_p(\Omega)$ bounds $\tau_p(\Omega)$ from below. On the other hand, when Ω is convex, $\tau_p(\Omega)$ can be bounded from above by a constant multiple of $w_p(\Omega)$, for some constant which tends to 1 as $p \rightarrow +\infty$. In fact, in [4] it is proved that, for any $p \in (1, +\infty)$, the following estimates hold and are sharp:

$$\forall \Omega \in \mathcal{C}, \quad \frac{q+1}{2^q} < \frac{w_p(\Omega)}{\tau_p(\Omega)} \leq 1 \quad (6)$$

where \mathcal{C} denotes the class of planar bounded convex domains; moreover the right inequality holds as an equality if and only if Ω is a disk. Note that, if $p \rightarrow +\infty$, then $q \rightarrow 1$ and the constant in the left hand side of (6) tends to 1.

In this paper, we prove some geometric estimates for $\tau_p(\Omega)$ in the class \mathcal{C} , which have some implications in the conjecture (4). More precisely, we consider the following shape functionals:

$$\Omega \mapsto \frac{\tau_p(\Omega)|\partial\Omega|^q}{|\Omega|^{q+1}} \quad \text{and} \quad \Omega \mapsto \frac{\tau_p(\Omega)}{R_\Omega^q|\Omega|} . \quad (7)$$

Let us remark that the above quotients are invariant under dilations and that convex sets which agree up to rigid motions (translations and rotations) are systematically identified throughout the paper.

Our main results are Theorems 1 and 6, which give sharp bounds for the functionals (7) when Ω varies in \mathcal{C} . We also exhibit minimizing and maximizing sequences. These bounds are obtained by combining sharp bounds for the web p -torsion (see Theorem 2 and the second part of Theorem 6) with (6). As a consequence of our results we obtain the validity of some weak forms of Pólya-Szegő conjecture (4). On the class \mathcal{P} of convex polygons we introduce a sort of “asymmetry measure” such as

$$\forall \Omega \in \mathcal{P}, \quad \gamma(\Omega) := \frac{|\partial\Omega|}{|\partial\Omega^*|} \in [1, +\infty),$$

where Ω^* denotes the regular polygon with the same area and the same number of vertices as Ω . Then, if the p -torsion $\tau_p(\Omega)$ is replaced by the web p -torsion $w_p(\Omega)$, (4) holds in the following refined form:

$$\forall \Omega \in \mathcal{P}, \quad w_p(\Omega) \leq \gamma(\Omega)^{-q} w_p(\Omega^*). \quad (8)$$

Consequently, on the class \mathcal{P}_N of convex polygons with N vertices, conjecture (4) holds true for those Ω which are sufficiently “far” from Ω^* , meaning that $\gamma(\Omega)$ exceeds a threshold depending on N and p :

$$\forall \Omega \in \mathcal{P}_N : \gamma(\Omega) \geq \Gamma_{N,p}, \quad \tau_p(\Omega) < \tau_p(\Omega^*). \quad (9)$$

The value of the threshold $\Gamma_{N,p}$ can be explicitly characterized (see Corollary 4) and tends to 1 as $p \rightarrow +\infty$. The paper is organized as follows. Section 2 contains the statement of our results, which are proved in Section 4 after giving in Section 3 some preliminary material of geometric nature. Section 5 is devoted to some related open questions and perspectives.

2 Results

We introduce the following classes of convex planar domains:

\mathcal{C} = the class of bounded convex domains in \mathbb{R}^2 ;

\mathcal{C}_o = the subclass of \mathcal{C} given by tangential bodies to a disk;

\mathcal{P} = the class of convex polygons;

\mathcal{P}_N = the class of convex polygons having N vertices ($N \geq 3$).

Tangential bodies to a disk are domains $\Omega \in \mathcal{C}$ such that, for some disk D , through each point of $\partial\Omega$ there exists a tangent line to Ω which is also tangent to D . Domains in $\mathcal{P} \cap \mathcal{C}_o$ are circumscribed polygons, whereas domains in $\mathcal{C}_o \setminus \mathcal{P}$ can be obtained by removing from a circumscribed polygon some connected components of the complement (in the polygon itself) of the inscribed disk. In particular, the disk itself belongs to \mathcal{C}_o .

Our first results are the following sharp bounds for the p -torsion of convex planar domains. We recall that, for any given $p \in (1, +\infty)$, $q := \frac{p}{p-1}$ denotes its conjugate exponent.

Theorem 1. *For any $p \in (1, +\infty)$, it holds*

$$\forall \Omega \in \mathcal{C}, \quad \frac{1}{q+1} < \frac{\tau_p(\Omega) |\partial\Omega|^q}{|\Omega|^{q+1}} < \frac{2^{q+1}}{(q+2)(q+1)}. \quad (10)$$

Moreover,

- the left inequality holds asymptotically with equality sign for any sequence of thinning rectangles;
- the right inequality holds asymptotically with equality sign for any sequence of thinning isosceles triangles.

By sequence of thinning rectangles or triangles, we mean that the ratio between their minimal width and diameter tends to 0. We point out that, in the particular case when $p = 2$, the statement of Theorem 1 is already known. Indeed, the left inequality in (10) holds true for any simply connected set in \mathbb{R}^2 as discovered by Pólya [12]; the right inequality in (10) for convex sets is due to Makai [11], though its method of proof, which is different from ours, does not allow to obtain the *strict* inequality.

Our approach to prove Theorem 1 employs as a major ingredient the following sharp estimates for the web p -torsion of convex domains, which may have their own interest.

Theorem 2. *For any $p \in (1, +\infty)$, it holds*

$$\forall \Omega \in \mathcal{C}, \quad \frac{1}{q+1} < \frac{w_p(\Omega)|\partial\Omega|^q}{|\Omega|^{q+1}} \leq \frac{2}{q+2}. \quad (11)$$

Moreover,

- the left inequality holds asymptotically with equality sign for any sequence of thinning rectangles;
- the right inequality holds with equality sign for $\Omega \in \mathcal{C}_o$.

Let us now discuss the implications of the above results in the shape optimization problem which consists in maximizing τ_p in the class of convex polygons with a given area and a given number of vertices:

$$\max \left\{ \tau_p(\Omega) : \Omega \in \mathcal{P}_N, |\Omega| = m \right\}. \quad (12)$$

We recall that, for any $\Omega \in \mathcal{P}$, Ω^\otimes denotes the regular polygon with the same area and the same number of vertices as Ω . Moreover, we set

$$\forall \Omega \in \mathcal{P}, \quad \gamma(\Omega) := \frac{|\partial\Omega|}{|\partial\Omega^\otimes|};$$

notice that by the isoperimetric inequality for polygons (see Proposition 7), $\gamma(\Omega) \in [1, +\infty)$ and $\gamma(\Omega) > 1$ if $\Omega \neq \Omega^\otimes$. With this notation, it is straightforward to deduce from Theorem 2 the following

Corollary 3. *The regular polygon is the unique maximizer of w_p over polygons in \mathcal{P} with a given area and a given number of vertices. More precisely, the following refined isoperimetric inequality holds:*

$$\forall \Omega \in \mathcal{P}, \quad w_p(\Omega) \leq \gamma(\Omega)^{-q} w_p(\Omega^\otimes). \quad (13)$$

As a consequence, using (6), we obtain some information on the shape optimization problem (12):

Corollary 4. *Let $\Gamma_{N,p} := \left(\frac{w_p(\Omega^\otimes)}{\tau_p(\Omega^\otimes)} \right)^{1/q} \frac{2}{(q+1)^{1/q}}$. Then,*

$$\forall \Omega \in \mathcal{P}_N, \quad \tau_p(\Omega) < \Gamma_{N,p}^q \gamma(\Omega)^{-q} \tau_p(\Omega^\otimes).$$

In particular, the p -torsion of the regular N -gon is larger than the p -torsion of any polygon in \mathcal{P}_N having the same area and an asymmetry measure larger than the threshold $\Gamma_{N,p}$:

$$\forall \Omega \in \mathcal{P}_N, \quad \gamma(\Omega) \geq \Gamma_{N,p} \Rightarrow \tau_p(\Omega) < \tau_p(\Omega^\otimes). \quad (14)$$

Some comments on Corollary 4 are gathered in the next remark.

Remark 5. (i) Using again (6) we infer

$$1 < \Gamma_{N,p} < \frac{2}{(q+1)^{1/q}} < 2 \quad \forall N, p, \quad \lim_{p \rightarrow +\infty} \Gamma_{N,p} = 1.$$

Hence, asymptotically with respect to p , the condition $\gamma(\Omega) \geq \Gamma_{N,p}$ appearing in (14) becomes not restrictive. Moreover, if $p = 2$, we have $\Gamma_{N,2} \leq 2/\sqrt{3} \approx 1.15$ and the dependence on N of $\Gamma_{N,2}$ can be enlightened by using the numerical values given in [6]:

N	3	4	5	6	7	8	9	10	20
$\Gamma_{N,2} \approx$	1.054	1.089	1.108	1.121	1.129	1.135	1.138	1.141	1.149

(ii) Though the validity of (4) is known for triangles, in order to give an idea of the efficiency of Corollary 4, consider the case $N = 3$ and $p = 2$. The equilateral triangle

$$T^{\otimes} := \left\{ (x, y) \in \mathbb{R}^2; y > 0, -\frac{1}{2} + \frac{y}{\sqrt{3}} < x < \frac{1}{2} - \frac{y}{\sqrt{3}} \right\}$$

satisfies $|T^{\otimes}| = \frac{\sqrt{3}}{4}$ and $|\partial T^{\otimes}| = 3$. The solution to (1) is explicitly given by

$$u(x, y) = \frac{\sqrt{3}}{8} \left(y - \frac{4}{\sqrt{3}}y^2 + \frac{4}{3}y^3 - 4x^2y \right)$$

so that $\tau_2(T^{\otimes}) = \sqrt{3}/640$. Moreover, by (27) below we find $w_2(T^{\otimes}) = \sqrt{3}/768$ and, in turn, that $\Gamma_{3,2} = \sqrt{10}/3 \approx 1.054$.

Consider now the isosceles triangles T_k having the basis of length $k > 0$ and the two equal sides of length

$$\ell_k = \sqrt{\frac{3}{4k^2} + \frac{k^2}{4}} \quad \text{so that} \quad |\partial T_k| = k + \sqrt{\frac{3}{k^2} + k^2} \quad \text{and} \quad |T_k| = \frac{\sqrt{3}}{4} = |T^{\otimes}|,$$

(notice that $T_1 = T^{\otimes}$). Therefore,

$$\gamma(T_k) = \frac{k + \sqrt{\frac{3}{k^2} + k^2}}{3}$$

and $\gamma(T_k) \geq \Gamma_{3,2}$ if and only if $2\sqrt{10}k^3 - 10k^2 + 3 \geq 0$, which approximatively corresponds to $k \notin (0.760, 1.301)$.

We conclude this section with a variant of Theorems 1 and 2.

Theorem 6. *For every $p \in (1, +\infty)$, it holds*

$$\forall \Omega \in \mathcal{C}, \quad \frac{1}{(q+2)2^{q-1}} \leq \frac{\tau_p(\Omega)}{R_{\Omega}^q |\Omega|} < \frac{2^q}{(q+1)^2} \quad (15)$$

$$\forall \Omega \in \mathcal{C}, \quad \frac{1}{(q+2)2^{q-1}} \leq \frac{w_p(\Omega)}{R_{\Omega}^q |\Omega|} < \frac{1}{q+1}. \quad (16)$$

Moreover,

- the left inequality in (15) holds with equality sign for balls;
- the left inequality in (16) holds with equality sign for $\Omega \in \mathcal{C}_o$;
- the right inequality in (16) holds asymptotically with equality sign for a sequence of thinning rectangles.

The right inequality in (15) is not sharp. In fact, for $p = 2$, one has the sharp inequalities

$$\forall \Omega \in \mathcal{C}, \quad \frac{1}{8} \leq \frac{\tau_2(\Omega)}{R_{\Omega}^2 |\Omega|} \leq \frac{1}{3},$$

see [13, p. 100] for the left one, and [11] for the right one.

Using the isoperimetric inequalities (15) and (16), one can also derive statements similar to Corollaries 3 and 4, where $\gamma(\Omega)$ is replaced by another ‘‘asymmetry measure’’ given by

$$\tilde{\gamma}(\Omega) = \frac{R_{\Omega^{\otimes}}}{R_{\Omega}}.$$

3 Geometric preliminaries

In this section we present some useful geometric properties of convex polygons, which will be exploited to prove Theorem 2. First, we recall an improved form of the isoperimetric inequality in the class \mathcal{P} , whose proof can be found for instance in [3, Theorem 2]. For any $\Omega \in \mathcal{P}$, we set

$$C_\Omega := \sum_i \cotan \frac{\theta_i}{2}, \quad \text{being } \theta_i \text{ the inner angles of } \Omega. \quad (17)$$

Proposition 7. *For every $\Omega \in \mathcal{P}$, it holds*

$$|\Omega| \leq \frac{|\partial\Omega|^2}{4C_\Omega}, \quad (18)$$

with equality sign if and only if $\Omega \in \mathcal{P} \cap \mathcal{C}_o$, namely when Ω is a circumscribed polygon.

Next, we recall that, denoting by R_Ω the inradius of any $\Omega \in \mathcal{P}$, for every $t \in [0, R_\Omega]$, the *inner parallel sets* of Ω are defined by

$$\Omega_t := \{x \in \Omega : \text{dist}(x, \partial\Omega) > t\}$$

(notice in particular that $\Omega_{R_\Omega} = \emptyset$). Then we focus our attention on the behaviour of the map $t \mapsto C_{\Omega_t}$ on the interval $[0, R_\Omega]$, and on the related expression of Steiner formulae. For every $\Omega \in \mathcal{P}$, we set

$$r_\Omega := \sup \{t \in [0, R_\Omega] : \Omega_t \text{ has the same number of vertices as } \Omega\}.$$

Clearly, if $r_\Omega < R_\Omega$, the number of vertices of Ω_t is strictly less than the number of vertices of Ω for every $t \in [r_\Omega, R_\Omega)$.

Proposition 8. *For every $\Omega \in \mathcal{P}$ and $t \geq 0$, $\Omega_t \in \mathcal{P}$ and the map $t \mapsto C_{\Omega_t}$ is piecewise constant on $[0, R_\Omega)$. Moreover, for every $t \in [0, r_\Omega]$, it holds*

$$|\Omega_t| = |\Omega| - |\partial\Omega|t + C_\Omega t^2 \quad \text{and} \quad |\partial\Omega_t| = |\partial\Omega| - 2C_\Omega t. \quad (19)$$

Finally, for every $t \in [0, R_\Omega]$, it holds

$$|\partial\Omega_t| \leq |\partial\Omega| - 2\pi t. \quad (20)$$

Proof. For t small enough, the sides of Ω_t are parallel and at distance t from the sides of Ω , and the corners of Ω_t are located on the bisectors of the angles of Ω . r_Ω is actually the first time when two of these bisectors intersect at a point having distance t from at least two sides, see Figure 1.

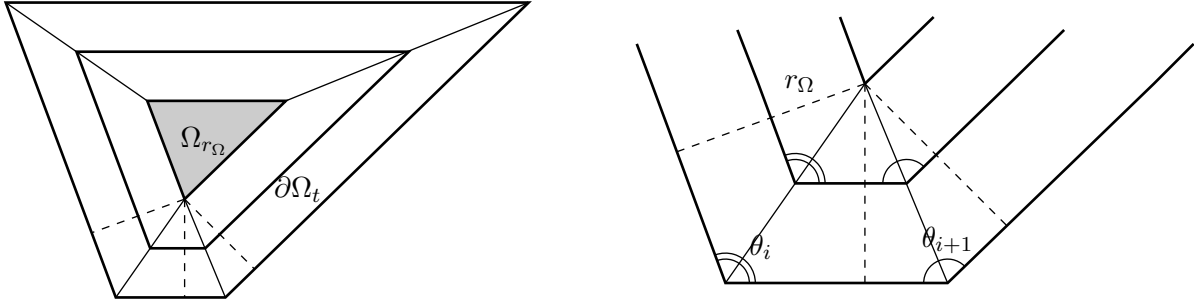

Figure 1: Intersection of bisectors

Therefore, for $t < r_\Omega$, Ω_t has the same angles as Ω (so $C_{\Omega_t} = C_\Omega$ by (17)), and we notice that the perimeter of grey areas in Figure 2 is $2t \cotan(\theta_i/2)$, and their areas are $t^2 \cotan(\theta_i/2)$, which gives (19) (still valid for $t = r_\Omega$ by continuity).

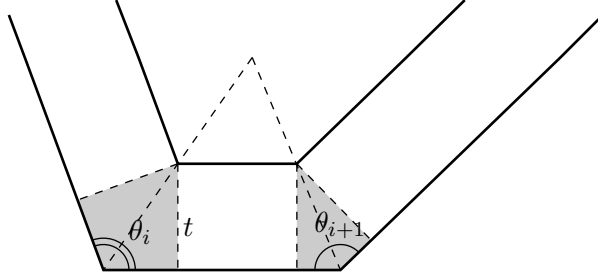

Figure 2: How to derive Steiner formulae

Let us now show that the map $t \mapsto C_{\Omega_t}$ is piecewise constant on $[0, R_\Omega)$, assuming that $r_\Omega < R_\Omega$. Once $t = r_\Omega$, Ω_t still has sides parallel to the ones of Ω but loses at least one of them. Again, C_{Ω_t} is constant for $t \geq r_\Omega$ until the next value of t such that another intersection of bisectors appears (we now consider bisectors of Ω_{r_Ω}). The number of discontinuities of $t \mapsto C_{\Omega_t}$ is finite since Ω has a finite number of sides, and therefore iterating the previous argument, we get that $t \mapsto C_{\Omega_t}$ is piecewise constant.

Finally, from (17) we infer that $C_\Omega \geq \pi$ for any $\Omega \in \mathcal{P}$, so that (20) follows from the concavity of the map $t \mapsto |\partial\Omega_t|$ on $[0, R_\Omega]$ (see [1, Sections 24 and 55]). \square

A special role is played by polygons $\Omega \in \mathcal{P}$ such that $r_\Omega = R_\Omega$, namely polygons Ω whose inner parallel sets all have the same number of vertices as Ω itself. These are *polygonal stadiums*, characterized by the following

Definition 9. We call \mathcal{S} the class of *polygonal stadiums*, namely polygons $P^\ell \in \mathcal{P}$ such that there exist a circumscribed polygon $P \in \mathcal{P} \cap \mathcal{C}_o$ having two parallel sides, and a nonnegative number ℓ such that, by choosing a coordinate system with origin in the center of the disk inscribed in P and the x -axis directed as two parallel sides of P , P^ℓ can be written as

$$P^\ell := \left(P_- - \left(\frac{\ell}{2}, 0 \right) \right) \cup \left(\left[-\frac{\ell}{2}, \frac{\ell}{2} \right] \times \left(-R_P, R_P \right) \right) \cup \left(P_+ + \left(\frac{\ell}{2}, 0 \right) \right), \quad (21)$$

where P_- (resp. P_+) denotes the set of points $(x, y) \in P$ with $x < 0$ (resp. $x > 0$), and R_P is the inradius of P , see Figure 3.

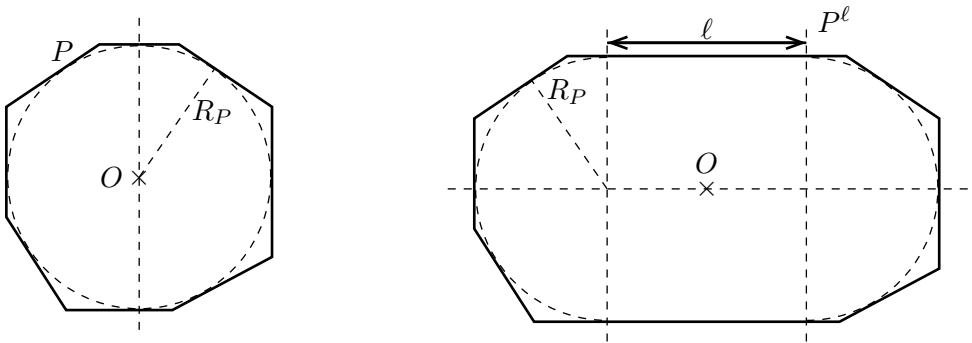

Figure 3: A circumscribed polygon P and a polygonal stadium P^ℓ

Proposition 10. Let $\Omega \in \mathcal{P}$. There holds $r_\Omega = R_\Omega$ if and only if $\Omega \in \mathcal{S}$.

Proof. We use the same notation as in Definition 9. Assume that $\Omega = P^\ell \in \mathcal{S}$. Then the bisectors of the angles of Ω intersect either at $(-\frac{\ell}{2}, 0)$ or at $(\frac{\ell}{2}, 0)$, which are at distance R_Ω from the boundary, see Figure 4. In particular, if Ω is circumscribed to a disk, namely if $\ell = 0$, then the bisectors of the angles of Ω all intersect at the center of the disk. Therefore, Ω_t has the same number of sides as Ω if $t < R_\Omega$.

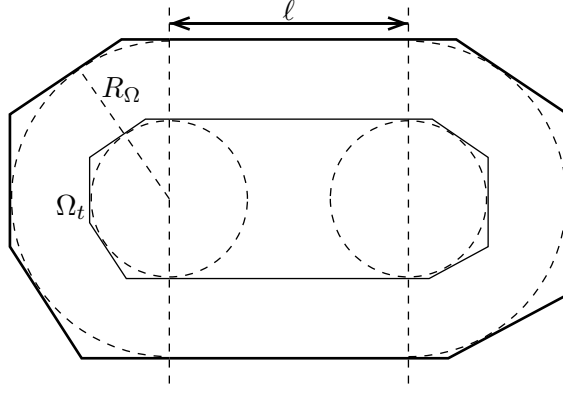

Figure 4: Parallel sets of a polygonal stadium P^ℓ

Conversely, assume that $R_\Omega = r_\Omega$. The set $\{x \in \Omega : d(x) = R_\Omega\}$ is convex with empty interior, so either it is a point, or a segment. If it is a point, then its distance to each side is the same, and therefore the disk having this point as a center and radius R_Ω is tangent to every side of Ω , so that Ω is circumscribed to a disk. If it is a segment, we choose coordinates such that this segment is $[-\frac{\ell}{2}, 0] \times (\frac{\ell}{2}, 0]$ for some positive number ℓ . Every point of this segment is at distance R_Ω from the boundary, so Ω contains the rectangle $(-\frac{\ell}{2}, \frac{\ell}{2}) \times (-R_\Omega, R_\Omega)$. Considering

$$P := \left(\Omega \cap \left\{ x \leq -\frac{\ell}{2} \right\} + \left(\frac{\ell}{2}, 0 \right) \right) \cup \left(\Omega \cap \left\{ x \geq \frac{\ell}{2} \right\} + \left(-\frac{\ell}{2}, 0 \right) \right),$$

we have that P is circumscribed and $\Omega = P^\ell$. □

Remark 11. Thanks to Proposition 10, for any polygonal stadium P^ℓ , the validity of the Steiner formulae (19) extends for t ranging over the whole interval $[0, R_{P^\ell}]$. Moreover, the value of the coefficients $|P^\ell|$, $|\partial P^\ell|$ and C_{P^ℓ} appearing therein, can be expressed only in terms of $|P|$, R_P , and ℓ (see Section 4). It is enough to use the following elementary equalities deriving from decomposition (21)

$$|P^\ell| = |P| + 2\ell R_P, \quad |\partial P^\ell| = |\partial P| + 2\ell, \quad C_{P^\ell} = C_P, \quad R_{P^\ell} = R_P,$$

and the following identities holding for every $P \in \mathcal{P} \cap \mathcal{C}_o$

$$C_P = \frac{|P|}{R_P^2}, \quad |\partial P| = \frac{2|P|}{R_P}. \quad (22)$$

Finally, we show that the parallel sets of any convex polygon Ω are polygonal stadiums for t sufficiently close to R_Ω :

Proposition 12. *For every $\Omega \in \mathcal{P}$, there exists $\bar{t} \in [0, R_\Omega)$ such that the parallel sets Ω_t belong to \mathcal{S} for every $t \in [\bar{t}, R_\Omega)$.*

Proof. We define \bar{t} as the last time $t < R_\Omega$ such that Ω loses a side (we may have $\bar{t} = 0$). Therefore $\forall t \in [\bar{t}, R_\Omega]$, Ω_t has a constant number of sides, and so is in the class \mathcal{S} by Proposition 10. □

4 Proofs

4.1 Proof of Theorem 2

We first prove Theorem 2 for $\Omega \in \mathcal{P}$, then we prove it for all $\Omega \in \mathcal{C}$.

• *Step 1: comparison with inner parallel sets.* For a given $\Omega \in \mathcal{P}$, we wish to compare the value of the energy $\frac{w_p(\Omega)|\partial\Omega|^q}{|\Omega|^{q+1}}$ with the one of its parallel set Ω_ε for small ε . To that aim, we use the representation formula (5) for $w_p(\Omega)$, and Steiner's formulae (19). In applying them we recall that, by Proposition 8 the map $t \mapsto C_{\Omega_t}$ is piecewise constant for $t \in [0, R_\Omega]$, and in particular it equals C_Ω on $[0, r_\Omega]$. Taking also into account that $(\Omega_\varepsilon)_t = \Omega_{\varepsilon+t}$, as $\varepsilon \rightarrow 0$ we have

$$\begin{aligned}
\frac{w_p(\Omega_\varepsilon)|\partial\Omega_\varepsilon|^q}{|\Omega_\varepsilon|^{q+1}} &= \frac{\int_0^{R_\Omega-\varepsilon} \frac{|(\Omega_\varepsilon)_t|^q}{|\partial(\Omega_\varepsilon)_t|^{q-1}} dt |\partial\Omega_\varepsilon|^q}{|\Omega_\varepsilon|^{q+1}} \\
&= \frac{\left[w_p(\Omega) - \int_0^\varepsilon \frac{|\Omega_t|^q}{|\partial\Omega_t|^{q-1}} dt \right] [|\partial\Omega| - 2C_\Omega \varepsilon]^q}{[|\Omega| - |\partial\Omega| \varepsilon]^{q+1}} + o(\varepsilon), \\
&= \frac{|\partial\Omega|^q}{|\Omega|^{q+1}} \left[w_p(\Omega) - \frac{|\Omega|^q}{|\partial\Omega|^{q-1}} \varepsilon \right] \left[1 - 2q \frac{C_\Omega}{|\partial\Omega|} \varepsilon \right] \left[1 + (q+1) \frac{|\partial\Omega|}{|\Omega|} \varepsilon \right] + o(\varepsilon), \\
&= \frac{w_p(\Omega)|\partial\Omega|^q}{|\Omega|^{q+1}} + \left[(q+1) \frac{|\partial\Omega|^{q+1}}{|\Omega|^{q+2}} w_p(\Omega) - \frac{|\partial\Omega|}{|\Omega|} - 2q \frac{C_\Omega w_p(\Omega)|\partial\Omega|^{q-1}}{|\Omega|^{q+1}} \right] \varepsilon + o(\varepsilon),
\end{aligned} \tag{23}$$

so that

$$\frac{w_p(\Omega_\varepsilon)|\partial\Omega_\varepsilon|^q}{|\Omega_\varepsilon|^{q+1}} - \frac{w_p(\Omega)|\partial\Omega|^q}{|\Omega|^{q+1}} = \left[(q+1) \frac{|\partial\Omega|^{q+1}}{|\Omega|^{q+2}} w_p(\Omega) - \frac{|\partial\Omega|}{|\Omega|} - 2q \frac{C_\Omega w_p(\Omega)|\partial\Omega|^{q-1}}{|\Omega|^{q+1}} \right] \varepsilon + o(\varepsilon). \tag{24}$$

As we shall see in the next steps, formula (24) will enable us to reach a contradiction if (11) fails.

• *Step 2: if (11) fails for some convex polygon then it also fails for a polygonal stadium.* Let $\Omega \in \mathcal{P} \setminus \mathcal{S}$, and assume that (11) fails. We have to distinguish two cases.

First case: Assume that

$$\frac{w_p(\Omega)|\partial\Omega|^q}{|\Omega|^{q+1}} > \frac{2}{q+2}. \tag{25}$$

Using the isoperimetric inequality (18) and (25), one gets

$$\left[(q+1) \frac{|\partial\Omega|^{q+1}}{|\Omega|^{q+2}} w_p(\Omega) - \frac{|\partial\Omega|}{|\Omega|} - 2q \frac{C_\Omega w_p(\Omega)|\partial\Omega|^{q-1}}{|\Omega|^{q+1}} \right] \geq \frac{q+2}{2} \frac{|\partial\Omega|}{|\Omega|} \left[\frac{w_p(\Omega)|\partial\Omega|^q}{|\Omega|^{q+1}} - \frac{2}{q+2} \right] > 0.$$

Inserting this information into (24) shows that

$$\frac{w_p(\Omega_\varepsilon)|\partial\Omega_\varepsilon|^q}{|\Omega_\varepsilon|^{q+1}} - \frac{w_p(\Omega)|\partial\Omega|^q}{|\Omega|^{q+1}} > 0$$

for sufficiently small ε . In fact, more can be said. By Proposition 8 we know that $C_{\Omega_t} = C_\Omega$ for all $t \in [0, r_\Omega]$. By extending the above argument to all such t , we obtain that, if (25) holds, then the map $t \mapsto \frac{w_p(\Omega_t)|\partial\Omega_t|^q}{|\Omega_t|^{q+1}}$ is strictly increasing for $t \in [0, r_\Omega]$. In particular, by (25),

$$\frac{w_p(\Omega_\varepsilon)|\partial\Omega_\varepsilon|^q}{|\Omega_\varepsilon|^{q+1}} > \frac{w_p(\Omega)|\partial\Omega|^q}{|\Omega|^{q+1}} > \frac{2}{q+2} \quad \forall \varepsilon \in (0, r_\Omega].$$

So, if $\Omega_{r_\Omega} \in \mathcal{S}$, we are done since it violates (11). At $t = r_\Omega$ the number of sides of Ω_t varies. If $\Omega_{r_\Omega} \notin \mathcal{S}$, we repeat the previous argument to the next interval where C_{Ω_t} remains constant. Again, the map $t \mapsto \frac{w_p(\Omega_t)|\partial\Omega_t|^q}{|\Omega_t|^{q+1}}$ is strictly increasing on such interval. In view of Proposition 12, this procedure enables us to obtain some polygonal stadium such that (25) holds.

Second case: Assume that

$$\frac{w_p(\Omega)|\partial\Omega|^q}{|\Omega|^{q+1}} \leq \frac{1}{q+1}. \tag{26}$$

Hence,

$$\begin{aligned} & \left[(q+1) \frac{|\partial\Omega|^{q+1}}{|\Omega|^{q+2}} w_p(\Omega) - \frac{|\partial\Omega|}{|\Omega|} - 2q \frac{C_\Omega w_p(\Omega) |\partial\Omega|^{q-1}}{|\Omega|^{q+1}} \right] \\ &= (q+1) \frac{|\partial\Omega|}{|\Omega|} \left[\frac{|\partial\Omega|^q}{|\Omega|^{q+1}} w_p(\Omega) - \frac{1}{q+1} - \frac{2q}{q+1} \frac{C_\Omega w_p(\Omega) |\partial\Omega|^{q-2}}{|\Omega|^q} \right] < 0. \end{aligned}$$

Inserting this into (24) and arguing as in the previous case, we see that the map $t \mapsto \frac{w_p(\Omega_t) |\partial\Omega_t|^q}{|\Omega_t|^{q+1}}$ is strictly decreasing for $t \in [0, R_\Omega)$. In view of Proposition 12, this proves that there exists some polygonal stadium such that (26) holds.

• *Step 3: explicit computation for a polygonal stadium.* Let $\Omega = P^\ell \in \mathcal{S}$ be a polygonal stadium. We are going to derive an explicit expression for the function

$$F(\ell) := \frac{w_p(P^\ell) |\partial P^\ell|^q}{|P^\ell|^{q+1}} \quad \forall \ell \geq 0.$$

We point out that, in the special case $\ell = 0$, $\Omega \in \mathcal{P} \cap \mathcal{C}_o$ (namely Ω is a circumscribed polygon), and it is proven in [4, Proposition 2] that

$$\forall \Omega \in \mathcal{C}_o, \quad \frac{w_p(\Omega) |\partial\Omega|^q}{|\Omega|^{q+1}} = \frac{2}{q+2}. \quad (27)$$

In particular, formula (27) shows that the upper bound in (11) is achieved when $\Omega \in \mathcal{C}_o$.

We now show that the above formula can be suitably extended also to the case $\ell > 0$. Our starting point is the representation formula (5). Therein, we use the Steiner formulae (19); in particular, by Propositions 8 and 10, we know that $C_{\Omega_t} \equiv C_\Omega$ for every $t \in [0, R_\Omega)$. Moreover, since $P \in \mathcal{P} \cap \mathcal{C}_o$, we can exploit identities (22). Setting for brevity

$$A := |P|, \quad R := R_P, \quad x := \frac{2R\ell}{A},$$

we obtain

$$\begin{aligned} F(\ell) &= \frac{(2\frac{A}{R} + 2\ell)^q}{(A + 2R\ell)^{q+1}} \int_0^R \frac{(A + 2R\ell - 2\ell t - 2\frac{A}{R}t + \frac{A}{R^2}t^2)^q}{(2\ell + 2\frac{A}{R}t - 2\frac{A}{R^2}t)^{q-1}} dt \\ &= \frac{(x+2)^q}{(x+1)^{q+1}} \int_0^1 \frac{(1+x-xt-2t+t^2)^q}{(x+2-2t)^{q-1}} dt \\ &= \frac{(x+2)^q}{(x+1)^{q+1}} \int_0^1 \frac{t^q(x+t)^q}{(x+2t)^{q-1}} dt. \end{aligned} \quad (28)$$

Of course, taking $x = 0$ in (28) gives again (27); on the other hand, taking $x \rightarrow \infty$ gives the asymptotic behaviour for thinning polygonal stadiums.

• *Step 4:* In view of equality (28) obtained in Step 3, the estimate (11) will be proved for any polygonal stadium, provided we show that for all $q \in (1, +\infty)$ one has

$$\frac{1}{q+1} < \frac{(x+2)^q}{(x+1)^{q+1}} \int_0^1 \frac{t^q(x+t)^q}{(x+2t)^{q-1}} dt < \frac{2}{q+2} \quad \forall x \in (0, +\infty). \quad (29)$$

With the change of variables $t = xs$, the inequalities in (29) become

$$\frac{1}{q+1} \frac{(x+1)^{q+1}}{x^{q+2}(x+2)^q} < \int_0^{1/x} \frac{s^q(1+s)^q}{(1+2s)^{q-1}} ds < \frac{2}{q+2} \frac{(x+1)^{q+1}}{x^{q+2}(x+2)^q} \quad \forall x \in (0, +\infty).$$

In turn, by putting $y = 1/x$, the latter inequalities become

$$\frac{1}{q+1} \frac{y^{q+1}(1+y)^{q+1}}{(1+2y)^q} < \int_0^y \frac{s^q(1+s)^q}{(1+2s)^{q-1}} ds < \frac{2}{q+2} \frac{y^{q+1}(1+y)^{q+1}}{(1+2y)^q} \quad \forall y \in (0, +\infty). \quad (30)$$

In order to prove the right inequality in (30), consider the function

$$\Phi(y) := \int_0^y \frac{s^q(1+s)^q}{(1+2s)^{q-1}} ds - \frac{2}{q+2} \frac{y^{q+1}(1+y)^{q+1}}{(1+2y)^q} \quad y \in (0, +\infty)$$

and we need to prove that $\Phi(y) < 0$ for all $y > 0$. This is a consequence of the two following facts:

$$\Phi(0) = 0, \quad \Phi'(y) = -\frac{q}{q+2} \frac{y^q(1+y)^q}{(1+2y)^{q+1}} < 0.$$

In order to prove the left inequality in (30), consider the function

$$\Psi(y) := \int_0^y \frac{s^q(1+s)^q}{(1+2s)^{q-1}} ds - \frac{1}{q+1} \frac{y^{q+1}(1+y)^{q+1}}{(1+2y)^q} \quad y \in (0, +\infty)$$

and we need to prove that $\Psi(y) > 0$ for all $y > 0$. This is a consequence of the two following facts:

$$\Psi(0) = 0, \quad \Psi'(y) = \frac{2q}{q+1} \frac{y^{q+1}(1+y)^{q+1}}{(1+2y)^{q+1}} > 0.$$

Both inequalities in (30) are proved and (29) follows.

We point out that, in the case $q = 2$, some explicit computations give the stronger result that the map

$$x \mapsto \frac{(x+2)^q}{(x+1)^{q+1}} \int_0^1 \frac{t^q(x+t)^q}{(x+2t)^{q-1}} dt$$

is decreasing. We believe that this is true for any q , but we do not have a simple proof of this property.

• *Step 5: conclusion.* Let $\Omega \in \mathcal{P}$ and assume for contradiction that Ω violates (11). Then by Step 2 we know that there exists a polygonal stadium which also violates (11). This contradicts Step 4, see (29). We have so far proved that (11) holds for all $\Omega \in \mathcal{P}$. By a density argument we then infer that

$$\forall \Omega \in \mathcal{C}, \quad \frac{1}{q+1} \leq \frac{w_p(\Omega)|\partial\Omega|^q}{|\Omega|^{q+1}} \leq \frac{2}{q+2}. \quad (31)$$

Therefore, in order to complete the proof we need to show that the left inequality in (31) is strict. Assume for contradiction that there exists $\Omega \in \mathcal{C}$ such that

$$\frac{w_p(\Omega)|\partial\Omega|^q}{|\Omega|^{q+1}} = \frac{1}{q+1}. \quad (32)$$

Take any sequence $\Omega_\varepsilon^k \in \mathcal{P}$ such that $\Omega_\varepsilon^k \supset \Omega$ and $\Omega_\varepsilon^k \rightarrow \Omega$ in the Hausdorff topology. Similar computations as in (23), combined with (20), enable us to obtain

$$\begin{aligned} \frac{w_p(\Omega_\varepsilon^k)|\partial\Omega_\varepsilon^k|^q}{|\Omega_\varepsilon^k|^{q+1}} &\leq \frac{\left[w_p(\Omega^k) - \int_0^\varepsilon \frac{|\Omega_t^k|^q}{|\partial\Omega_t^k|^{q-1}} dt \right] \left[|\partial\Omega^k| - 2\pi\varepsilon \right]^q}{\left[|\Omega^k| - |\partial\Omega^k|_\varepsilon \right]^{q+1}} \\ &\leq \frac{w_p(\Omega^k)|\partial\Omega^k|^q}{|\Omega^k|^{q+1}} + \left[(q+1) \frac{|\partial\Omega^k|^{q+1}}{|\Omega^k|^{q+2}} w_p(\Omega^k) - \frac{|\partial\Omega^k|}{|\Omega^k|} - 2q \frac{\pi w_p(\Omega^k)|\partial\Omega^k|^{q-1}}{|\Omega^k|^{q+1}} \right] \varepsilon + \alpha\varepsilon^2, \end{aligned}$$

where α is some positive constant, depending on Ω but not on k . Therefore, since $\Omega_t^k \rightarrow \Omega_t$ for all $t \in [0, R_\Omega]$, we have

$$\begin{aligned} \frac{w_p(\Omega_\varepsilon)|\partial\Omega_\varepsilon|^q}{|\Omega_\varepsilon|^{q+1}} - \frac{w_p(\Omega)|\partial\Omega|^q}{|\Omega|^{q+1}} &= \frac{w_p(\Omega_\varepsilon^k)|\partial\Omega_\varepsilon^k|^q}{|\Omega_\varepsilon^k|^{q+1}} - \frac{w_p(\Omega^k)|\partial\Omega^k|^q}{|\Omega^k|^{q+1}} + o(1) \\ &\leq \left[o(1) - 2q \frac{\pi w_p(\Omega^k)|\partial\Omega^k|^{q-1}}{|\Omega^k|^{q+1}} \right] \varepsilon + \alpha\varepsilon^2 + o(1) \end{aligned}$$

where $o(1)$ are infinitesimals (independent of ε) as $k \rightarrow \infty$. Hence, by letting $k \rightarrow \infty$ and taking ε sufficiently small, we obtain $\frac{w_p(\Omega_\varepsilon)|\partial\Omega_\varepsilon|^q}{|\Omega_\varepsilon|^{q+1}} < \frac{1}{q+1}$, which contradicts (31).

4.2 Proof of Theorem 1

The inequalities (10) follow directly from (11) and (6) so we just need to show that they are sharp.

For the right inequality, take a sequence of thinning isosceles triangles T_k . Then, by Theorem 2 we have

$$\frac{w_p(T_k)|\partial T_k|^q}{|T_k|^{q+1}} = \frac{2}{q+2} \quad \text{for all } k.$$

On the other hand, by [4, Proposition 3] and (6) we know that

$$\lim_{k \rightarrow \infty} \frac{w_p(T_k)}{\tau_p(T_k)} = \frac{q+1}{2^q}$$

and therefore

$$\lim_{k \rightarrow \infty} \frac{\tau_p(T_k)|\partial T_k|^q}{|T_k|^{q+1}} = \frac{2^{q+1}}{(q+2)(q+1)}.$$

For the left inequality, we seek an upper bound for $\tau_p(\Omega)$ by using the maximum principle. For all $\ell \in (0, +\infty)$ let $\Omega^\ell = (-\frac{\ell}{2}, \frac{\ell}{2}) \times (-1, 1)$ and let u_ℓ be the unique solution to

$$-\Delta_p u_\ell = 1 \quad \text{in } \Omega^\ell, \quad u_\ell = 0 \quad \text{on } \partial\Omega^\ell.$$

Let $u_\infty(x, y) = \frac{p-1}{p}(1 - |y|^{p/(p-1)})$ so that

$$-\Delta_p u_\infty = 1 \quad \text{in } \Omega^\ell, \quad u_\infty \geq 0 \quad \text{on } \partial\Omega^\ell.$$

By the maximum principle, we infer that $u_\infty \geq u_\ell$ in Ω^ℓ so that

$$\tau_p(\Omega^\ell) = \int_{\Omega^\ell} u_\ell \leq \int_{\Omega^\ell} u_\infty = \frac{2(p-1)}{p} \ell \int_0^1 (1 - y^{p/(p-1)}) dy = \frac{2(p-1)}{2p-1} \ell = \frac{2\ell}{q+1}.$$

Hence,

$$1 \geq \liminf_{\ell \rightarrow \infty} \frac{w_p(\Omega^\ell)}{\tau_p(\Omega^\ell)} \geq \liminf_{\ell \rightarrow \infty} \frac{(q+1)w_p(\Omega^\ell)}{2\ell} = 1$$

where the last equality follows from Theorem 2. Combined with Theorem 2, this proves that

$$\lim_{\ell \rightarrow \infty} \frac{\tau_p(\Omega^\ell)|\partial\Omega^\ell|^q}{|\Omega^\ell|^{q+1}} = \frac{1}{q+1}.$$

4.3 Proof of Theorem 6

Since it follows closely the proof of Theorem 1, we just sketch it. We first prove the counterpart of Theorem 2 and we follow the same steps.

• *Step 1.* Given $\Omega \in \mathcal{P}$ and using $R_{\Omega_\varepsilon} = R_\Omega - \varepsilon + o(\varepsilon)$ we prove:

$$\frac{w_p(\Omega_\varepsilon)}{R_{\Omega_\varepsilon}|\Omega_\varepsilon|} - \frac{w_p(\Omega)}{R_\Omega|\Omega|} = \frac{\varepsilon}{R_\Omega^q|\Omega|} \left(w_p(\Omega) \left[\frac{q}{R_\Omega} + \frac{|\partial\Omega|}{|\Omega|} \right] - \frac{|\Omega|^q}{|\partial\Omega|^{q-1}} \right) + o(\varepsilon). \quad (33)$$

• *Step 2.* We prove that, if (16) fails for some $\Omega \in \mathcal{P}$, then it also fails for a polygonal stadium. To that end, we estimate the sign in (33) with the help of the following classical geometric inequalities (see [1])

$$\forall \Omega \in \mathcal{C}, \quad \frac{|\Omega|}{R_\Omega} < |\partial\Omega| \leq \frac{2|\Omega|}{R_\Omega}.$$

• *Step 3.* Again, explicit computations can be done for a polygonal stadium, and with the same notation as in the proof of Theorem 2, we get:

$$\frac{w_p(P^\ell)}{R_{P^\ell}^q|P^\ell|} = \frac{1}{x+1} \int_0^1 \frac{t^q(x+t)^q}{(x+2t)^{q-1}} dt \quad \forall P^\ell \in \mathcal{S}.$$

• *Step 4.* In view of Step 3, estimate (15) is proved for any polygonal stadium, provided for all $q \in (1, +\infty)$ one has

$$\frac{1}{(q+2)2^{q-1}} < \frac{1}{x+1} \int_0^1 \frac{t^q(x+t)^q}{(x+2t)^{q-1}} dt < \frac{1}{q+1} \quad \forall x \in (0, +\infty). \quad (34)$$

With the change of variables $t = xs$ and putting $y = 1/x$, the inequalities in (34) become

$$\frac{y^{q+2} + y^{q+1}}{(q+2)2^{q-1}} < \int_0^y \frac{s^q(1+s)^q}{(1+2s)^{q-1}} ds < \frac{y^{q+2} + y^{q+1}}{q+1} \quad \forall y \in (0, +\infty). \quad (35)$$

Some tedious but straightforward computations show that

$$\frac{y^{q+1}}{2^{q-1}} + \frac{q+1}{(q+2)2^{q-1}} y^q < \frac{y^q(1+y)^q}{(1+2y)^{q-1}} < \frac{q+2}{q+1} y^{q+1} + y^q \quad \forall y \in (0, +\infty)$$

and (35) follows after integration over $(0, y)$.

• *Step 5.* The previous steps leads to (16) for polygons and by density for convex domains. The strict right inequality in (16) can be obtained by reproducing carefully the computations in Step 1, similarly as done in Step 5 of Section 4.1.

Now the counterpart of Theorem 2 is proved, and we may use (6) in order to get (15) from (16). Balls realize equality in the left inequality of (15) because the are at the same time circumscribed and maximal for the quotient w_p/τ_p .

5 Some open problems

We briefly suggest here some perspectives which might be considered, in the light of our results.

Sharp bounds for the p -torsion in higher dimensions. In higher dimensions the shape functionals τ_p and w_p can be defined in the analogous way as for $n = 2$. In [2], Crasta proved the following sharp bounds:

$$\forall \Omega \text{ bounded convex set} \subset \mathbb{R}^n, \quad \frac{n+1}{2n} < \frac{w_2(\Omega)}{\tau_2(\Omega)} \leq 1.$$

Therefore it seems natural to ask: what kind of isoperimetric inequality can be proved for w_p and τ_p among convex sets in \mathbb{R}^n ? In this direction, let us quote an inequality proven in [7], obtained by a strategy similar to our approach, that is by looking at the level sets of the support function:

$$\forall \Omega \text{ bounded convex set } \subset \mathbb{R}^n, \quad \frac{\tau_2(\Omega)|\partial\Omega|}{R_\Omega|\Omega|^2} \geq \frac{\tau_2(B)|\partial B|}{R_B|B|^2} \quad (B \text{ is a ball of } \mathbb{R}^n).$$

Sharp bounds for the principal frequency. A notion of “web principal frequency” can be defined (in any space dimension) similarly as done for the web torsion, that is

$$\lambda_1^+(\Omega) := \inf \left\{ \frac{\int_\Omega |\nabla u|^2}{\int_\Omega u^2} : u \in \mathcal{W}_2(\Omega) \right\}.$$

Writing the optimality condition in the space $\mathcal{W}_2(\Omega)$, one can express $\lambda_1^+(\Omega)$ as

$$\lambda_1^+(\Omega) = \inf \left\{ \frac{\int_0^{R_\Omega} \alpha \rho'^2}{\int_0^{R_\Omega} \alpha \rho^2} : \rho \in H^1(0, R_\Omega), \rho(0) = 0 \right\}, \text{ where } \alpha(t) = |\partial\Omega_t|.$$

It is clear that $\lambda_1^+(\Omega) \geq \lambda_1(\Omega)$, with equality sign when Ω is a ball. On the other hand, the following questions can be addressed:

- Find a sharp bound from above for the ratio $\lambda_1^+(\Omega)/\lambda_1(\Omega)$ among bounded convex subsets of \mathbb{R}^n .
- Is it possible to apply successfully the same strategy of this paper, that is find sharp bounds for $\lambda_1^+(\Omega)$ and then use the estimates on the ratio $\lambda_1^+(\Omega)/\lambda_1(\Omega)$, to deduce sharp bounds for $\lambda_1(\Omega)$? In particular, this approach might allow to retrieve the following known inequalities holding for any bounded convex domain $\Omega \subset \mathbb{R}^2$ (see [10, 11, 12]):

$$\frac{\pi^2}{16} \leq \lambda_1(\Omega) \frac{|\Omega|^2}{|\partial\Omega|^2} \leq \frac{\pi^2}{4} \quad \text{and} \quad \frac{\pi^2}{4} \leq \lambda_1(\Omega) R_\Omega^2 \leq j_0^2.$$

Acknowledgments. This work was realized thanks to the financial support of the Italian Gruppo Nazionale per l’Analisi Matematica, la Probabilità e le loro Applicazioni, as part of the project “Problemi di ottimizzazione e disuguaglianze geometrico-funzionali”, and by the French Agence Nationale de la Recherche, as part of the project ANR-09-BLAN-0037 “Geometric analysis of optimal shapes”.

References

- [1] T. Bonnesen, W. Fenchel, *Theory of convex bodies*, BSC Associates, Moscow, Idaho, 1987
- [2] G. Crasta, *Estimates for the energy of the solutions to elliptic Dirichlet problems on convex domains*, Proc. Roy. Soc. Edinburgh Sect. A 134, 2004, 89-107
- [3] G. Crasta, I. Fragalà, F. Gazzola, *A sharp upper bound for the torsional rigidity of rods by means of web functions*, Arch. Rat. Mech. Anal. 164, 2002, 189-211
- [4] G. Crasta, I. Fragalà, F. Gazzola, *On the role of energy convexity in the web function approximation*, Nonlin. Diff. Eq. Appl. 12, 2005, 93-109
- [5] G. Crasta, F. Gazzola, *Some estimates of the minimizing properties of web functions*, Calculus of Variations 15, 2002, 45-66
- [6] G. Crasta, F. Gazzola, *Web functions: survey of results and perspectives*, Rend. Ist. Mat. Univ. Trieste 33, 2001, 313-326

- [7] P. Freitas, D. Krejčířík, *A sharp upper bound for the first Dirichlet eigenvalue and the growth of the Isoperimetric Constant of convex domains*, Proc. American Math. Soc. 136, 2008, 2997-3006
- [8] F. Gazzola, *Existence of minima for nonconvex functionals in spaces of functions depending on the distance from the boundary*, Arch. Rat. Mech. Anal. 150, 1999, 57-76
- [9] A. Henrot, *Extremum problems for eigenvalues of elliptic operators*, Birkäuser Verlag, Basel, 2006
- [10] J. Hersch, *Sur la fréquence fondamentale d'une membrane vibrante: évaluations par défaut et principe de maximum*, Z. Angew. Math. Phys. 11, 1960, 387-413
- [11] E. Makai, *On the principal frequency of a membrane and the torsional rigidity of a beam*, Studies in mathematical analysis and related topics, 227-231, Stanford Univ. Press, Stanford, Calif. 1962
- [12] G. Pólya, *Two more inequalities between physical and geometrical quantities*, J. Indian Math. Soc. (N.S.) 24, 1960, 413-419
- [13] G. Pólya, G. Szegő, *Isoperimetric Inequalities in Mathematical Physics*, Princeton University Press, Princeton, 1951
- [14] A.Y. Solynin, V.A. Zalgaller, *An isoperimetric inequality for logarithmic capacity of polygons*, Ann. of Math. (2) 159, 2004, 277-303

Ilaria FRAGALÀ, Politecnico di Milano, Piazza Leonardo da Vinci 32, 20133 Milano (Italy)

Filippo GAZZOLA, Politecnico di Milano, Piazza Leonardo da Vinci 32, 20133 Milano (Italy)

Jimmy LAMBOLEY, Université Paris-Dauphine, Ceremade, Place du Maréchal de Lattre de Tassigny, 75775 Paris (France)